



WEST VIRGINIA DEPARTMENT OF TRANSPORTATION

Division of Highways

1900 Kanawha Boulevard East • Building Five • Room 110
Charleston, West Virginia 25305-0430 • (304) 558-3505

Joe Manchin III
Governor

RECEIVED
JAN 27 2010
ENGINEERING DIVISION
WV DOH

January 25, 2010

MEMORANDUM

TO: DD
All District Design Engineers

FROM: DT 

SUBJECT: Changes to Bid Item Listing and Standard Details for Pavement Markings

This memo is to advise project design engineers and other applicable personnel of numerous changes related to the bid item listings for temporary and permanent pavement markings that have gone into effect.

Many of these changes are needed in order to coordinate with an ongoing update to the standard detail sheets related to pavement markings. Other specific changes to the bid item list are needed to eliminate obsolete items or items that are otherwise unnecessary and no longer needed. An additional number of changes are a result of recommended improvements to be made to the list that have been noted over a period of time.

Please note that some of the changes that are being made to the bid item listing render portions of the terminology in the current standard details obsolete. Revisions to the applicable standard details have been substantially completed and our division is in the process of going through the appropriate procedures to get the new standards officially adopted. In addition to this, our Division is working in conjunction with Contract Administration in regards to further revisions to the standard specifications related to pavement markings. Designers should also expect updated directions in the near future in regards to the Division's policy regarding the type of markings to be specified on particular projects.

A complete detailed listing of the current bid items for pavement markings, as well as notes regarding the proper use of these items and the aforementioned changes to the list is attached. The most current updated versions of Standard Detail Sheets TEM-1, TEM-2, TEM-3, and TEM-4 are also attached to this document. Note, the TEM-X labels have been removed from these sheets and they have also been relabeled as "Special Details". The details may assist in answering questions that you may have in regards to the revised item list.

Pavement Marking Bid Changes

January 25, 2010

Page Two

Designers should begin using the updated bid items for pavement markings immediately. The bid items shown on the attachment noted as being flagged as obsolete will remain unflagged until March 1, 2010. All projects submitted to be let on or after this date will be required to be modified in order to incorporate the revisions to the bid item list, in particular to eliminate the use of the bid items that are now obsolete. This includes projects for which the design process has been completed, but has not yet been PS&E'd, as well as projects that have been PS&E'd, but have not yet been advertised.

For projects incorporating the changes to the bid item listing, designers should review the attached special details and insert those that are applicable for their project. Please forward this memo to applicable personnel in your organization. Applicable personnel should also forward this information to outside consultants responsible for preparing project plans which would include these items.

If you have any questions regarding this memo, please contact Josh Hemsworth of this Division at (304) 558-9445.

CLC:Tj

Attachments

cc: DD-I, DD-R, PC, PC (Ron Stanevich), PM, All District Materials Supervisors, All District Construction Engineers, All DTE's, DT (Monty Kahn, Mike Spolarich, Josh Hemsworth, Bruce Kenney, Tim Kirk)

UPDATED LIST OF TRAFFIC PAVEMENT MARKING BID ITEMS (1/25/2010)

TEMPORARY MARKING BID ITEMS

ITEM NUMBER	DESCRIPTION	UM	SUPP. DESCRIPT.	NOTES
636008-001	TEMPORARY PAVEMENT MARKING- PAINT 4 IN	LF		Dashed lines and solid lines of the same width are to be paid for using the same bid item number. No separate item numbers for different colors. Payment is to be made for the actual footage of line placed.
636008-002	TEMPORARY PAVEMENT MARKING- PAINT 6 IN	LF		
636008-011	TEMPORARY PAVEMENT MARKING- PAINT 8 IN	LF		
636008-012	TEMPORARY PAVEMENT MARKING- PAINT 6 IN DASHED LINE	LF		THIS ITEM IS BEING FLAGGED AS OBSOLETE AND SHOULD NO LONGER BE USED.
636009-001	TEMPORARY PAVEMENT MARKING- TAPE 4 IN	LF	Y	These three items collectively are the only three items that should be used for temporary lines when temporary tape is specified. Designers are to include a supplemental description with these specifying either "Type VIIB" or "Type VIIC" No separate item numbers for different colors. Temporary tape is to be paid based on the actual footage of tape placed.
636009-002	TEMPORARY PAVEMENT MARKING- TAPE 6 IN	LF	Y	
636009-011	TEMPORARY PAVEMENT MARKING- TAPE 8 IN	LF	Y	
636010-003	TEMPORARY RAISED PAVEMENT MARKER, TYPE TCZ	EA		
636012-001	RAISED PAVEMENT MARKER	EA		THIS ITEM IS BEING FLAGGED AS OBSOLETE AND SHOULD NO LONGER BE USED.
636009-002	RAISED PAVEMENT MARKERS REFLECTORS WM	EA		THIS ITEM IS BEING FLAGGED AS OBSOLETE AND SHOULD NO LONGER BE USED.
636009-003	RAISED PAVEMENT MARKER REFLECTORS WR	EA		THIS ITEM IS BEING FLAGGED AS OBSOLETE AND SHOULD NO LONGER BE USED.
636009-101	TEMPORARY PVMT MARKINGS TAPE 4"	LF		THIS ITEM IS BEING FLAGGED AS OBSOLETE AND SHOULD NO LONGER BE USED.

UPDATED LIST OF TRAFFIC PAVEMENT MARKING BID ITEMS (1/25/2010)

PERMANENT MARKING BID ITEMS

ITEM NUMBER	DESCRIPTION	UM	SUPP. DESCRIPT.	NOTES
663001-002	EDGE LINE, TYPE I - 4 IN	MI	Y	This bid item is reserved for use only as part of the Division's annual striping maintenance Contracts.
663001-003	EDGE LINE, TYPE I - 4 IN	LF	Y	
663001-004	EDGE LINE, TYPE II - 4 IN	LF	Y	
663001-005	EDGE LINE, TYPE II - 4 IN	MI	Y	
663001-008	EDGE LINE, TYPE IV	LF		THIS ITEM IS BEING FLAGGED AS OBSOLETE AND SHOULD NO LONGER BE USED.
663001-010	EDGE LINE, TYPE V	LF	Y	Note, designers are to include an additional supplemental description with this item specifying the line width.
663001-011	EDGE LINE, TYPE V	MI		THIS ITEM IS BEING FLAGGED AS OBSOLETE AND SHOULD NO LONGER BE USED.
663001-018	EDGE LINE, TYPE IX - 4 IN	MI	Y	THIS ITEM IS BEING FLAGGED AS OBSOLETE AND SHOULD NO LONGER BE USED.
663001-019	EDGE LINE, TYPE IX - 4 IN	LF	Y	
663001-020	EDGE LINE, TYPE X - 4IN	MI	Y	This bid item is reserved for use only as part of the Division's annual striping maintenance Contracts.
663001-021	EDGE LINE, TYPE X - 4 IN	LF	Y	
663001-022	EDGE LINE, TYPE XI - 4 IN	LF	Y	
663001-023	EDGE LINE, TYPE XI - 4 IN	MI	Y	This bid item is reserved for use only as part of the Division's annual striping maintenance Contracts.
663001-024	EDGE LINE, TYPE I - 6 IN	LF	Y	
663001-025	EDGE LINE, TYPE I - 6 IN	MI	Y	This bid item is reserved for use only as part of the Division's annual striping maintenance Contracts.
663001-026	EDGE LINE, TYPE II - 6 IN	LF	Y	
663001-027	EDGE LINE, TYPE II - 6 IN	MI	Y	This bid item is reserved for use only as part of the Division's annual striping maintenance Contracts.
663001-028	EDGE LINE, TYPE IX - 6 IN	LF	Y	
663001-029	EDGE LINE, TYPE IX - 6 IN	MI	Y	This bid item is reserved for use only as part of the Division's annual striping maintenance Contracts.
663001-030	EDGE LINE, TYPE X - 6 IN	LF	Y	
663001-031	EDGE LINE, TYPE X - 6 IN	MI	Y	This bid item is reserved for use only as part of the Division's annual striping maintenance Contracts.
663001-032	EDGE LINE, TYPE XI - 6 IN	LF	Y	
663001-033	EDGE LINE, TYPE XI - 6 IN	MI	Y	This bid item is reserved for use only as part of the Division's annual striping maintenance Contracts.
663001-034	EDGE LINE, TYPE II - 8 IN	FT	Y	
663001-035	EDGE LINE, TYPE IX - 8 IN	FT	Y	
663001-036	EDGE LINE, TYPE X - 8 IN	FT	Y	
663001-037	EDGE LINE, TYPE XI - 8 IN	FT	Y	

Note separate bid items are provided based on the combination of material type and line width to be specified with the exception of Type V material (separate bid items for different widths are not given).
 Designers are to include a supplemental description with these items specifying either "white" or "yellow"

UPDATED LIST OF TRAFFIC PAVEMENT MARKING BID ITEMS (1/25/2010)

PERMANENT MARKING BID ITEMS (CONTINUED)

ITEM NUMBER	DESCRIPTION	UM	SUPP. DESCRIPT.	NOTES
663002-002	LANE LINE , TYPE I - 4 IN	LF		
663002-003	LANE LINE , TYPE I - 4 IN	MI		This bid item is reserved for use only as part of the Division's annual striping maintenance Contracts.
663002-004	LANE LINE , TYPE II - 4 IN	MI		This bid item is reserved for use only as part of the Division's annual striping maintenance Contracts.
663002-005	LANE LINE , TYPE II - 4 IN	LF		
663002-008	LANE LINE , TYPE IV	MI		THIS ITEM IS BEING FLAGGED AS OBSOLETE AND SHOULD NO LONGER BE USED.
663002-010	LANE LINE , TYPE V	LF	Y	Note, designers are to include a supplemental description with this item specifying the line width.
663002-018	LANE LINE , TYPE IX - 4 IN	MI		This bid item is reserved for use only as part of the Division's annual striping maintenance Contracts.
663002-019	LANE LINE , TYPE IX - 4 IN	LF		
663002-020	LANE LINE , TYPE X - 4 IN	MI		This bid item is reserved for use only as part of the Division's annual striping maintenance Contracts.
663002-021	LANE LINE , TYPE X - 4 IN	LF		
663002-022	LANE LINE , TYPE XI - 4 IN	MI		This bid item is reserved for use only as part of the Division's annual striping maintenance Contracts.
663002-023	LANE LINE , TYPE XI - 4 IN	LF		
663002-024	LANE LINE , TYPE I - 6 IN	LF		
663002-025	LANE LINE , TYPE I - 6 IN	MI		This bid item is reserved for use only as part of the Division's annual striping maintenance Contracts.
663002-026	LANE LINE , TYPE II - 6 IN	LF		
663002-027	LANE LINE , TYPE II - 6 IN	MI		This bid item is reserved for use only as part of the Division's annual striping maintenance Contracts.
663002-028	LANE LINE , TYPE IX - 6 IN	LF		
663002-029	LANE LINE , TYPE IX - 6 IN	MI		This bid item is reserved for use only as part of the Division's annual striping maintenance Contracts.
663002-030	LANE LINE , TYPE X - 6 IN	LF		
663002-031	LANE LINE , TYPE X - 6 IN	MI		This bid item is reserved for use only as part of the Division's annual striping maintenance Contracts.
663002-032	LANE LINE , TYPE XI - 6 IN	LF		
663002-033	LANE LINE , TYPE XI - 6 IN	MI		This bid item is reserved for use only as part of the Division's annual striping maintenance Contracts.

Note separate bid items are provided based on the combination of material type and line width to be specified with the exception of Type V material (separate bid items for different widths are not given).

No color supplemental description is needed.

Payment is to be made for the actual footage of line placed.

UPDATED LIST OF TRAFFIC PAVEMENT MARKING BID ITEMS (1/25/2010)

PERMANENT MARKING BID ITEMS (CONTINUED)

ITEM NUMBER	DESCRIPTION	UM	SUPP. DESCIP.	NOTES
663002-034	CENTERLINE, TYPE I, 4 IN	LF		<p>This bid item is reserved for use only as part of the Division's annual striping maintenance Contracts.</p> <p>This bid item is reserved for use only as part of the Division's annual striping maintenance Contracts.</p> <p>This bid item is reserved for use only as part of the Division's annual striping maintenance Contracts.</p> <p>Note separate bid items are provided based on the combination of material type and line width to be specified.</p> <p>No color supplemental description is needed.</p> <p>Payment is to be made for the actual footage of line placed. For clarification, each individual yellow line seperating two way traffic on a <u>undivided</u> roadway is to be considered a centerline. This includes the lines delineating a two way center left turn lane (the turn lane in this case is delineated by two solid and two dashed centerlines).</p>
663002-035	CENTERLINE, TYPE I, 4 IN	MI		
663002-036	CENTERLINE, TYPE I, 6 IN	LF		
663002-037	CENTERLINE, TYPE I, 6 IN	MI		
663002-038	CENTERLINE, TYPE II, 4 IN	LF		
663002-039	CENTERLINE, TYPE II, 4 IN	MI		
663002-040	CENTERLINE, TYPE II, 6 IN	LF		
663002-041	CENTERLINE, TYPE II, 6 IN	MI		
663002-042	CENTERLINE, TYPE V, 4 IN	LF		
663002-043	CENTERLINE, TYPE IX, 4 IN	LF		
663002-044	CENTERLINE, TYPE IX, 4 IN	MI		
663002-045	CENTERLINE, TYPE IX, 6 IN	LF		
663002-046	CENTERLINE, TYPE IX, 6 IN	MI		
663002-047	CENTERLINE, TYPE X, 4 IN	LF		
663002-048	CENTERLINE, TYPE X, 4 IN	MI		
663002-049	CENTERLINE, TYPE X, 6 IN	LF		
663002-050	CENTERLINE, TYPE X, 6 IN	MI		
663002-051	CENTERLINE, TYPE XI, 4IN	LF		
663002-052	CENTERLINE, TYPE XI, 4 IN	MI		
663002-053	CENTERLINE, TYPE XI, 6IN	LF		
663002-054	CENTERLINE, TYPE XI, 6 IN	MI		
663003-004	BARRIER LINE, TYPE II	MI	THIS ITEM IS BEING FLAGGED AS OBSOLETE AND SHOULD NO LONGER BE USED.	
663003-005	BARRIER LINE, TYPE II	LF	THIS ITEM IS BEING FLAGGED AS OBSOLETE AND SHOULD NO LONGER BE USED.	
663003-011	BARRIER LINE, TYPE V	LF	THIS ITEM IS BEING FLAGGED AS OBSOLETE AND SHOULD NO LONGER BE USED.	
663003-023	BARRIER LINE, TYPE XI	LF	THIS ITEM IS BEING FLAGGED AS OBSOLETE AND SHOULD NO LONGER BE USED.	

UPDATED LIST OF TRAFFIC PAVEMENT MARKING BID ITEMS (1/25/2010)

PERMANENT MARKING BID ITEMS (CONTINUED)

ITEM NUMBER	DESCRIPTION	UM	SUPP. DESCIP.	NOTES
663004-003	CHANNELIZING LINE, TYPE I - 8 IN	LF		
663004-004	CHANNELIZING LINE, TYPE II	LF		THIS ITEM IS BEING FLAGGED AS OBSOLETE AND SHOULD NO LONGER BE USED.
663004-011	CHANNELIZING LINE, TYPE V - 8 IN	LF		
663004-018	CHANNELIZING LINE, TYPE IX	LF		THIS ITEM IS BEING FLAGGED AS OBSOLETE AND SHOULD NO LONGER BE USED.
663004-019	CHANNELIZING LINE, TYPE IX	MI		THIS ITEM IS BEING FLAGGED AS OBSOLETE AND SHOULD NO LONGER BE USED.
663004-022	CHANNELIZING LINE, TYPE XI	MI		THIS ITEM IS BEING FLAGGED AS OBSOLETE AND SHOULD NO LONGER BE USED.
663005-008	STOP LINE, TYPE IV	LF		THIS ITEM IS BEING FLAGGED AS OBSOLETE AND SHOULD NO LONGER BE USED.
663005-010	STOP LINE, TYPE V - 12 IN	LF		
663005-011	STOP LINE, TYPE V - 24 IN	LF		
663006-004	CROSSWALK LINE, TYPE II	LF		THIS ITEM IS BEING FLAGGED AS OBSOLETE AND SHOULD NO LONGER BE USED.
663006-010	CROSSWALK LINE, TYPE V, 12 IN x 6 FT	LF		
663007-004	STRIPE, TYPE II	LF		THIS ITEM IS BEING FLAGGED AS OBSOLETE AND SHOULD NO LONGER BE USED.
663007-008	STRIPE, TYPE IV	LF		THIS ITEM IS BEING FLAGGED AS OBSOLETE AND SHOULD NO LONGER BE USED.
663007-010	STRIPE, TYPE V, 12 IN	LF	Y	Designers are to include a supplemental description specifying either "white" or "yellow"
663007-015	STRIPE, TYPE VIIIB	LF		THIS ITEM IS BEING FLAGGED AS OBSOLETE AND SHOULD NO LONGER BE USED.
663007-019	STRIPE, TYPE IX	LF		THIS ITEM IS BEING FLAGGED AS OBSOLETE AND SHOULD NO LONGER BE USED.
663008-005	YIELD TRIANGLE, TYPE V	EA		
663009-015	HANDICAPPED SYMBOL, TYPE V	EA		
663009-025	BICYCLE SYMBOL, TYPE V	EA		
663010-010	ONE DIRECTION LANE ASSIGNMENT ARROW, TYPE V	EA		Single arrow head lane assignment arrow (typically left or right turn).
663010-011	MULTI DIRECTIONAL LANE ASSIGNMENT ARROW, TYPE V	EA		Double or triple headed lane assignment arrows (typically right / straight combination or left / straight combination). Each marking to be paid as one unit regardless of the number of arrow heads on it.
663010-012	RAMP WRONG WAY ARROW, TYPE V	EA		To facilitate more accurate bidding, note individual bid items for four individual types of arrows are now provided. These arrows are detailed on the new pavement marking Standard Detail sheets.
663010-013	LANE DROP ARROW, TYPE V	EA		
663011-010	LANE LETTER, TYPE V	EA		

UPDATED LIST OF TRAFFIC PAVEMENT MARKING BID ITEMS (1/25/2010)

PERMANENT MARKING BID ITEMS (CONTINUED)

ITEM NUMBER	DESCRIPTION	UM	SUPP. DESCRIPT.	NOTES
663012-016	RAISED PAVEMENT MARKER, TYPE C-4	EA		THIS ITEM IS BEING FLAGGED AS OBSOLETE AND SHOULD NO LONGER BE USED.
663012-017	RAISED PAVEMENT MARKER, TYPE C-4NR	EA		THIS ITEM IS BEING FLAGGED AS OBSOLETE AND SHOULD NO LONGER BE USED.
663012-018	RAISED PAVEMENT MARKER, TYPE C-4R	EA		THIS ITEM IS BEING FLAGGED AS OBSOLETE AND SHOULD NO LONGER BE USED.
663012-025	RAISED PAVEMENT MARKER, TYPE C-6NR	EA		THIS ITEM IS BEING FLAGGED AS OBSOLETE AND SHOULD NO LONGER BE USED.
663012-026	RAISED PAVEMENT MARKER, TYPE C-6R	EA		THIS ITEM IS BEING FLAGGED AS OBSOLETE AND SHOULD NO LONGER BE USED.
663012-116	RAISED PAVEMENT MARKER, TYPE R-4	EA		
663012-208	RAISED PAVEMENT MARKER, TYPE P-2	EA		
663012-212	RAISED PAVEMENT MARKER REFLECTOR WR	EA		THIS ITEM IS BEING FLAGGED AS OBSOLETE AND SHOULD NO LONGER BE USED.
663013-004	SLOTTED MARKER, TYPE S	EA		
663015-005	RAILROAD CROSSING MARKING, TYPE V	EA		

PUBLIC WORKS DIV.	STATE PROJ. NO.	FEDERAL PROJ. NO.	FISCAL YEAR	COUNTY	SHEET NO.	TOTAL SHEETS

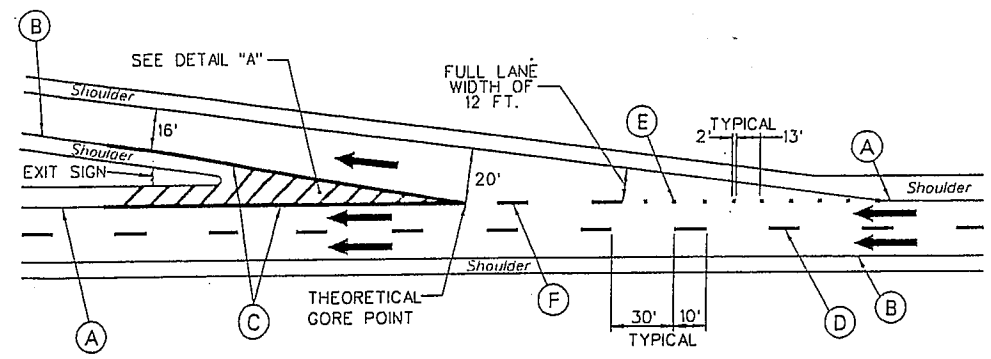

EXIT RAMP: STRAIGHT TAPERED DECELERATION LANE

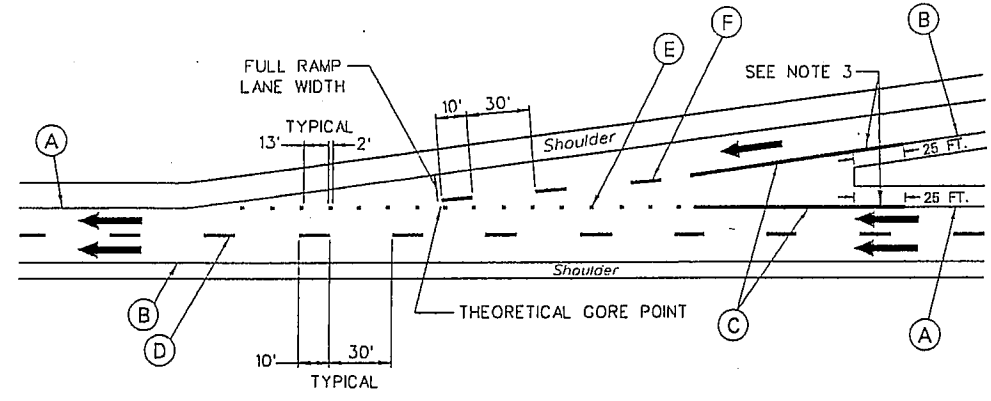

ENTRANCE RAMP: TAPERED ACCELERATION LANE

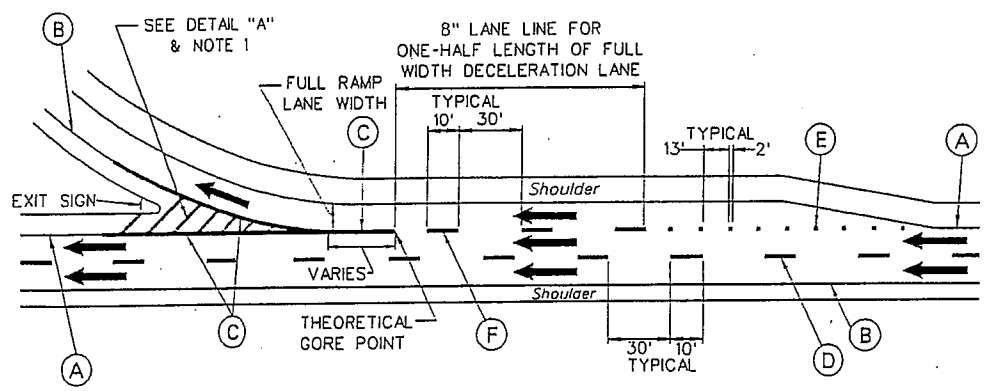

EXIT RAMP: PARALLEL DECELERATION LANE

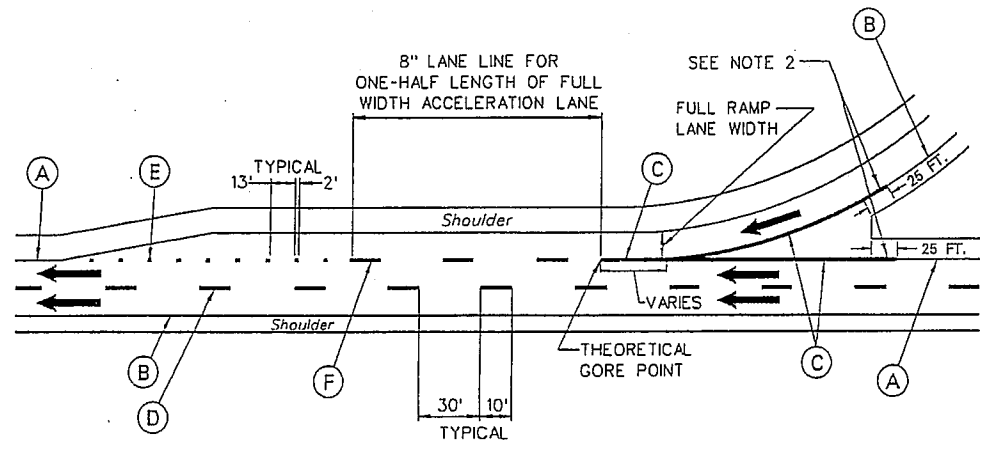

ENTRANCE RAMP: PARALLEL ACCELERATION LANE

NOTE: THIS ARROW ONLY INDICATES DIRECTION OF TRAVEL.

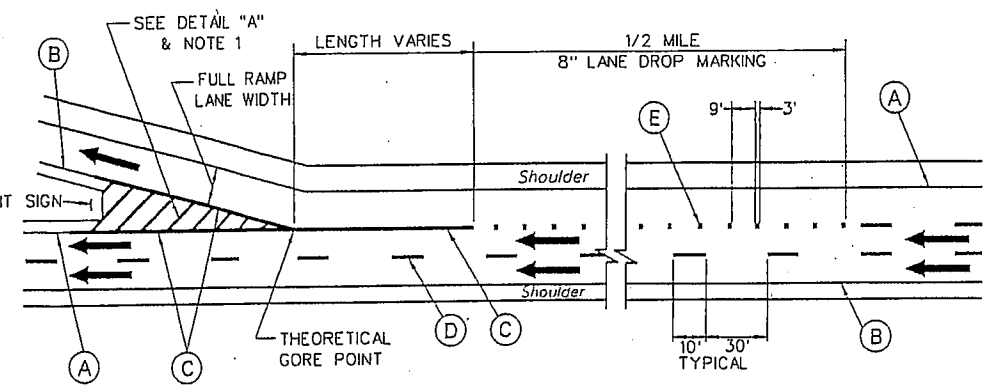

EXIT RAMP: LANE DROP

GENERAL NOTES

1. THE 8" EDGE LINE SHALL BE EXTENDED TO A POINT APPROXIMATELY 25' BEYOND THE EXIT SIGN ON BOTH SIDES OF THE GORE.
2. THE 8" EDGE LINE ON BOTH SIDES OF THE ENTRANCE RAMP GORE SHALL BE PLACED BEGINNING AT A POINT APPROXIMATELY 25' BEFORE THE POINT WHERE THE RAMP AND MAINLINE SHOULDER AREAS JOIN AND EXTEND TO AN APPROPRIATE POINT BEYOND WHERE THE 8" LINES MERGE INTO ONE LINE.
3. THE 8" EDGE LINE ON BOTH SIDES OF THE ENTRANCE RAMP GORE SHALL BE PLACED BEGINNING AT A POINT APPROXIMATELY 25' BEFORE THE POINT WHERE THE RAMP AND MAINLINE SHOULDER AREAS JOIN AND EXTEND FOR APPROXIMATELY ONE-HALF THE LENGTH TO THE THEORETICAL GORE POINT.
4. MARKINGS SHOWN ON THE CONTRACT PLANS OR DIRECTED TO BE INSTALLED BY THE PROJECT ENGINEER SHALL TAKE PRECEDENCE OVER THE DETAILS SHOWN ON THIS SHEET.
5. THIS DIMENSION SHALL BE 12 FEET UNLESS OTHERWISE SPECIFIED.
6. ALL MATERIALS UTILIZED SHALL BE IN COMPLIANCE WITH THE PROJECT PLANS. IF NOT SPECIFIED IN PROJECT PLANS, ALL MATERIALS SHALL BE IN COMPLIANCE W/THE STANDARD SPECIFICATIONS.

LEGEND

- (A) - ITEM 663001-*, EDGE LINE (6" WHITE)
- (B) - ITEM 663001-*, EDGE LINE (6" YELLOW)
- (C) - ITEM 663001-*, EDGE LINE (8" WHITE)
- (D) - ITEM 663002-*, LANE LINE (6")
- (E) - ITEM 663002-*, LANE LINE (8" DASHED)
- (F) - ITEM 663002-*, LANE LINE (8")

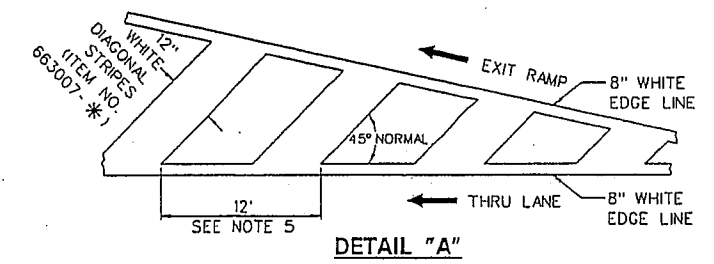

**WEST VIRGINIA DIVISION OF HIGHWAYS
SPECIAL DETAIL
TYPICAL MARKINGS OF
INTERCHANGE RAMPS**

PREPARED 12/9/10

REVISIONS

REPLACES STANDARD DETAILS BOOK
VOL. II SHEET TEM-1

PUBLIC ROADS DIV.	STATE DIST. NO.	STATE PROJECT NO.	FEDERAL PROJECT NO.	FISCAL YEAR	COUNTY	SHEET NO.	TOTAL SHEETS

GENERAL NOTES

- BROKEN LINES SHALL BE 10" IN LENGTH WITH 30' SPACINGS, UNLESS OTHERWISE SPECIFIED. THE RATIO OF PAINTED LINE LENGTH TO SKIP LENGTH SHALL BE 1 TO 3.
- THE DISTANCE FROM THE RAILROAD CROSSING MARKING TO THE NEAREST TRACK WILL VARY ACCORDING TO THE APPROACH SPEED AND THE SIGHT DISTANCE OF THE VEHICULAR TRAFFIC APPROACHING, BUT SHOULD NOT BE LESS THAN 50 FEET, ALSO SEE TABLE.
- ALL RAILROAD MARKINGS AND LINES SHALL BE WHITE. ON MULTI-LANE ROADS THE 2' WIDE TRANSVERSE LINES AND STOP LINES SHALL EXTEND ACROSS ALL APPROACH LANES, AND INDIVIDUAL RAILROAD SYMBOLS SHALL BE USED IN EACH APPROACH LANE.
- STOP LINES SHALL BE 12 INCHES IF SPEED LIMIT IS LESS THAN 45 MPH AND 24 INCHES IF SPEED LIMIT IS 45 MPH OR GREATER. ALL INTERCHANGE RAMP STOP LINES SHALL BE 24". STOP LINES SHOULD BE PLACED 4 FEET IN ADVANCE OF AND PARALLEL TO THE NEAREST CROSSWALK LINE. THE STOP LINE SHOULD BE PLACED AT THE DESIRED STOPPING POINT, BUT IN NO CASE MORE THAN 30 FEET OR LESS THAN 4 FEET FROM THE NEAREST EDGE OF THE INTERSECTING TRAVEL WAY.
- SUPPLEMENTAL PAVEMENT WORD AND/OR SYMBOL MARKINGS SHOULD BE LIMITED TO NOT MORE THAN A TOTAL OF THREE LINES OF INFORMATION (WORDS AND/OR SYMBOLS). THEY SHALL BE WHITE IN COLOR. LETTERS, SYMBOLS AND NUMERALS SHALL BE A MINIMUM OF 8" IN HEIGHT. THE WORD MARKING "ONLY" AND THE ARROW SHALL BE USED WHERE A MOVEMENT THAT WOULD OTHERWISE BE LEGAL IS TO BE PROHIBITED. THE SPACE BETWEEN LINES SHOULD BE AT LEAST FOUR TIMES THE HEIGHT OF THE CHARACTERS FOR LOW SPEEDS BUT NOT MORE THAN TEN TIMES THE HEIGHT OF THE CHARACTERS UNDER ANY CONDITIONS. LOCATION OF SUPPLEMENTAL PAVEMENT MARKINGS SHALL BE AS SHOWN BELOW OR AS DIMENSIONED ON THE PLANS.
- PASSING ZONES ARE WARRANTED WHERE THE SIGHT DISTANCE IS EQUAL TO OR GREATER THAN THE MINIMUM NECESSARY FOR SAFE PASSING. FOR FURTHER GUIDANCE SEE SECTION 3B OF THE MUTCD.
- THE SPACING BETWEEN ADJACENT YELLOW CENTERLINE MARKINGS SHALL BE EQUAL TO THE LINE WIDTHS (4" OR 6").
- ALL LONGITUDINAL MARKINGS SHALL BE OFFSET FROM THE PAVEMENT JOINTS AS SPECIFIED IN THE STANDARD SPECIFICATIONS.
- NORMALLY, THE MAXIMUM LANE WIDTH SHALL BE 12', EXCEPT A SINGLE-LANE RAMP WIDTH SHALL BE 16'.
- DUAL LEFT TURN LANES SHALL BE SEPARATED BY DASHED WHITE LINES 2' LONG WITH 6' SPACES. THE WIDTH OF THE DASHES SHALL BE EQUAL TO THE WIDTH OF THE LINE THAT THE DASHES ORIGINATE FROM.
- LEFT TURN MOVEMENTS MAY BE GUIDED BY DASHED YELLOW LINES 2' LONG WITH 6' SPACES WHERE ENGINEERING JUDGEMENT DETERMINES THAT SUCH ADDITIONAL MARKINGS ARE NEEDED. THE WIDTH OF THE DASHES SHALL BE EQUAL TO THE WIDTH OF THE LINE THAT THE DASHES ORIGINATE FROM.
- A TWO-WAY LEFT-TURN LANE-USE ARROW PAVEMENT MARKING, WITH OPPOSING ARROWS SPACED AS SHOWN, SHALL BE PLACED AT OR JUST DOWNSTREAM FROM THE BEGINNING OF THE TWO-WAY LEFT-TURN LANE ON EACH END. ADDITIONAL TWO-WAY LEFT-TURN LANE-USE ARROW MARKINGS MAY BE USED AT OTHER LOCATIONS ALONG A TWO-WAY LEFT-TURN LANE WHERE ENGINEERING JUDGEMENT DETERMINES THAT SUCH ADDITIONAL MARKINGS ARE NEEDED TO EMPHASIZE THE PROPER USE OF THE LANE.

LEGEND

- | | |
|---|---|
| (A) - ITEM 663001-*, EDGE LINE (4" WHITE) | (G) - ITEM 663001-*, EDGE LINE (6" WHITE) |
| (B) - ITEM 663002-*, LANE LINE (4" WHITE) | (H) - ITEM 663002-*, CENTERLINE (6" YELLOW) |
| (C) - ITEM 663002-*, CENTERLINE (4" YELLOW) | (I) - ITEM 663002-*, CENTERLINE (6" YELLOW) |
| (D) - ITEM 663002-*, CENTERLINE (4" YELLOW) | (J) - ITEM 663004-*, CHANNELIZING LINE (8") |
| (E) - ITEM 663001-*, EDGE LINE (6" YELLOW) | (K) - ITEM 663005-*, STOP LINE (12") |
| (F) - ITEM 663002-*, LANE LINE (6" WHITE) | (L) - ITEM 663005-*, STOP LINE (24") |

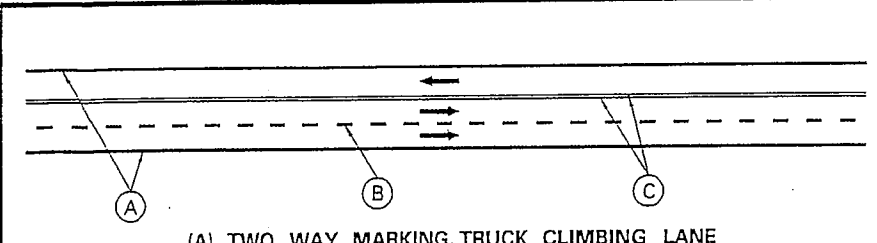

(A) TWO WAY MARKING, TRUCK CLIMBING LANE

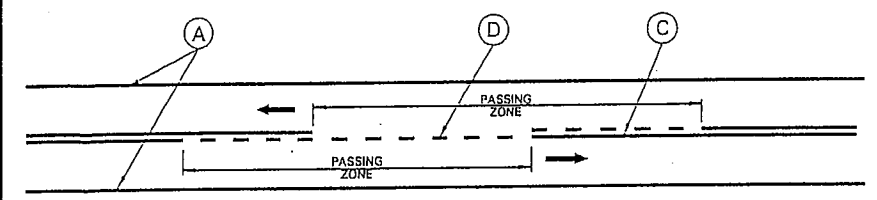

(B) TWO WAY MARKING FOR PASSING ZONE

(SEE NOTE 8)

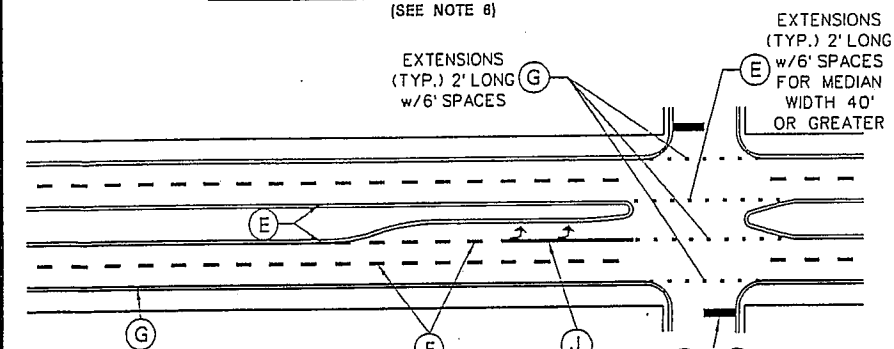

(C) DIVIDED HIGHWAY WITH MEDIAN

- USE WHEN SHOULDER PRESENT
- USE WHEN CURB PRESENT
- USE WITH EMERGENCY STOPPING LANE
- DO NOT USE WITH PARKING LANE

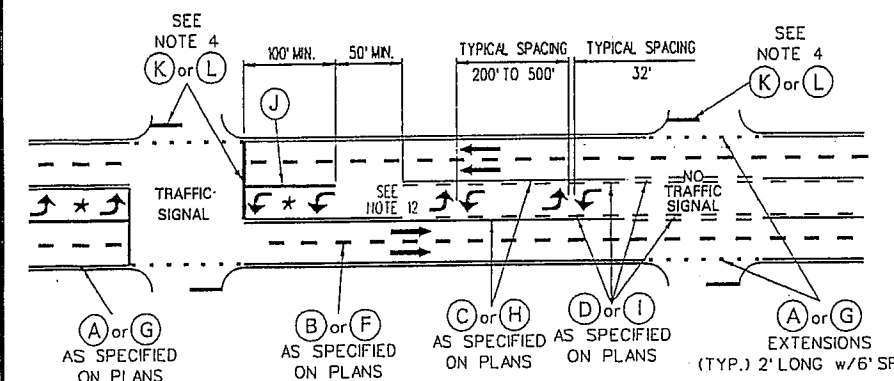

(D) MULTI-LANE HIGHWAY WITH TWO-WAY LEFT TURN CHANNELIZATION

NOTE:
WITH THE EXCEPTION OF THE 2' WIDE WHITE LINES SHOWN, ENTIRE RAILROAD MARKING TO BE PAID UNDER ITEM 663015-*. EACH 2' WIDE TRANSVERSE WHITE LINE TO BE PAID FOR AS 2 EA. ITEM 663007-010. FOR MORE DETAILS SEE TEM 3.

STOP LINES ARE LOCATED PERPENDICULAR TO ROADWAY AT APPROX. 15' (OR 8' FROM AND PARALLEL TO GATE IF PRESENT)

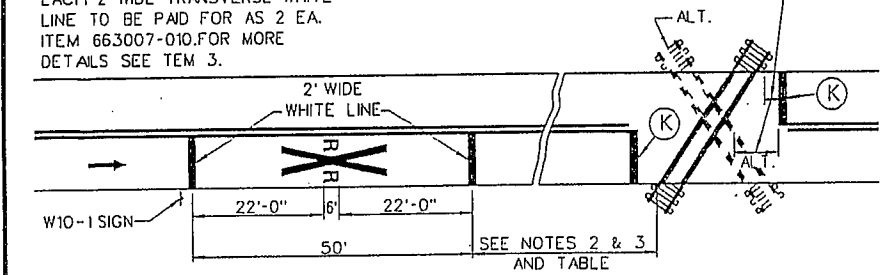

(E) TWO WAY MARKING, RAILROAD-HIGHWAY GRADE CROSSINGS

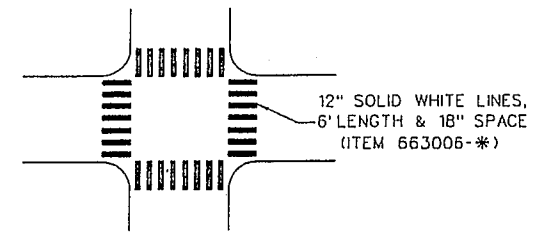

(F) TYPE V PARALLEL CROSSWALK LINE DETAILS

(OFFSET MARKINGS AS REQUIRED IN ORDER TO AVOID WHEEL TRACKING AREAS)

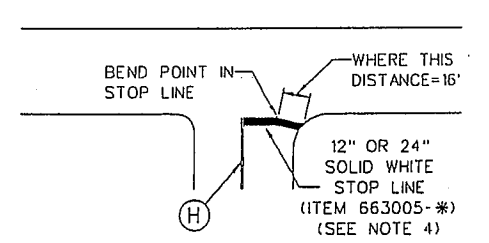

(G) METHODOLOGY FOR INSTALLING (BENDING) STOP LINES AT WIDE THROATED INTERSECTIONS

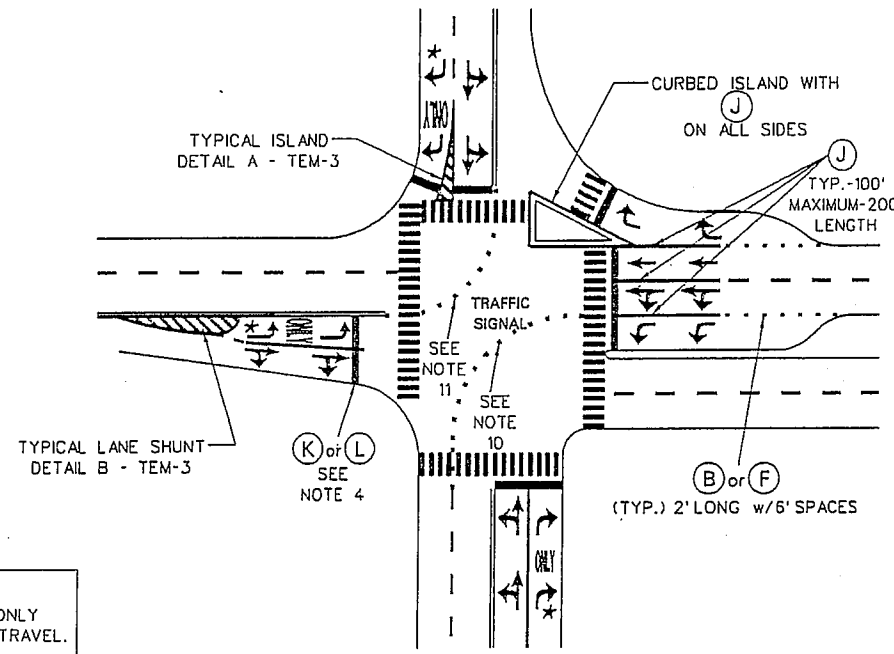

NOTE: IF A RAILROAD CROSSING IS CLOSE TO THE INTERSECTION PLACE ARROWS SO THAT DRIVERS ARE NOT DIRECTED ONTO TRACKS.

(H) TYPICAL INTERSECTIONS MARKINGS

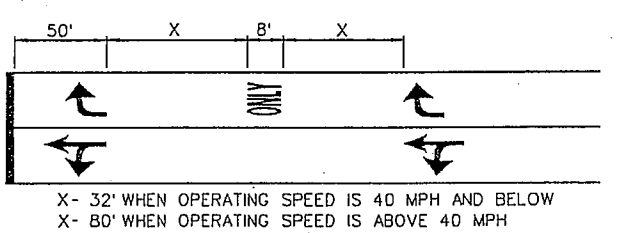

(I) TYPICAL LANE-USE MARKING

NOTE:
← THIS ARROW ONLY INDICATES DIRECTION OF TRAVEL.

NOTE:
* REQUIRED LANE-USE MARKINGS. ALL OTHER LANE USE ARROWS SHOWN ON THIS SHEET ARE OPTIONAL AS CALLED FOR ON PLANS.

RAILROAD CROSSING MARKING DISTANCE TABLE

POSTED OR 85TH PERCENTILE TRAFFIC SPEED	DISTANCE FROM NEAR RAIL TO MARKING
20	100**
25	100**
30	100
35	100
40	125
45	175
50	250
55	325
60	400

NOTE:
VALUES SHOWN ARE FOR GUIDANCE. ENGINEERING JUDGEMENT IS TO BE USED IN DETERMINING THE MARKING PLACEMENT TO ASSURE EFFECTIVENESS.

** - THIS DISTANCE MAY BE REDUCED TO A MINIMUM OF 50' DEPENDING UPON LOCAL CONDITIONS. A MINIMUM OF 100' IS GENERALLY NECESSARY FOR THE EFFECTIVE DISPLAY OF PAVEMENT MARKINGS. IF THE 100' MINIMUM CANNOT BE OBTAINED, MARKINGS MAY BE OMITTED.

WEST VIRGINIA DIVISION OF HIGHWAYS
SPECIAL DETAIL
TYPICAL PAVEMENT
MARKINGS

PREPARED 12/9/10

REVISIONS

REPLACES STANDARD DETAILS BOOK
VOL. II SHEET TEM-2

PUBLIC ROADS DIV.	STATE DIST. NO.	STATE PROJECT NO.	FEDERAL PROJECT NO.	FISCAL YEAR	COUNTY	SHEET NO.	TOTAL SHEETS

GENERAL NOTES

1. LOCATION OF WORDS AND SYMBOLS SHALL BE AS SHOWN ON THE PLANS OR AS OTHERWISE SPECIFIED.
2. TYPICAL PLACEMENT OF WORD AND SYMBOL MARKINGS IS SHOWN ON STANDARD SHEET TEM-2.
3. IF MESSAGES ON PAVEMENT CONSIST OF MORE THAN ONE WORD IT SHOULD BE READ "UP", THAT IS THE FIRST WORD SHOULD BE NEAREST THE DRIVER.
4. ALL WORD AND SYMBOL MARKINGS SHALL BE WHITE IN COLOR. (EXCEPTION: MARKINGS VISIBLE ONLY TO TRAFFIC PROCEEDING IN THE WRONG DIRECTION MAY BE RED).
5. WORD AND SYMBOL MARKINGS SHALL BE MADE OF TYPE V MARKINGS AS INDICATED ON THE CONTRACT PLANS.
6. THIS DIMENSION SHALL BE 12 FEET UNLESS OTHERWISE SPECIFIED, IN NO CASE SHALL THIS DIMENSION BE LESS THAN 8 FEET OR GREATER THAN 12 FEET.
7. WHERE LENGTH WILL PERMIT, TWO (2) FREEWAY RAMP ARROWS SHALL BE PLACED ON EXIT RAMP. THE NO. 1 ARROW SHOULD BE PLACED NEAR THE INTERSECTION OF THE RAMP AND THE INTERSECTING CROSSROAD (50' MIN.), BUT PRIOR TO THE BEGINNING OF ANY LANE SEPARATION CHANNELIZING LINES AT THE END OF THE RAMP. THE NO. 2 ARROW SHOULD BE PLACED NOT LESS THAN 100 FEET, BUT NOT MORE THAN 250 FEET PRIOR TO THE NO. 1 ARROW, WITH 150'-200' DESIRABLE. NO. 2 ARROW SHALL NOT BE PLACED ON RAMP IN FRONT OF "EXIT" SIGN. ARROWS SHOULD BE LOCATED IN FIELD WITHIN LIMITS MENTIONED ABOVE, TAKING ADVANTAGE OF RAMP GRADE AND ALIGNMENT. ARROWS SHALL BE CENTERED BETWEEN THE EDGE LINES, AND SHALL POINT IN THE DIRECTION OF THE INTENDED TRAFFIC FLOW.
8. YIELD MARKINGS SHOULD BE PLACED AT THE DESIRED YIELD POINT AS NEAR AS POSSIBLE TO THE INTERSECTING ROADWAY, BUT IN NO CASE MORE THAN 30 FEET OR LESS THAN 4 FEET FROM THE NEAREST EDGE OF THE INTERSECTING ROADWAY.

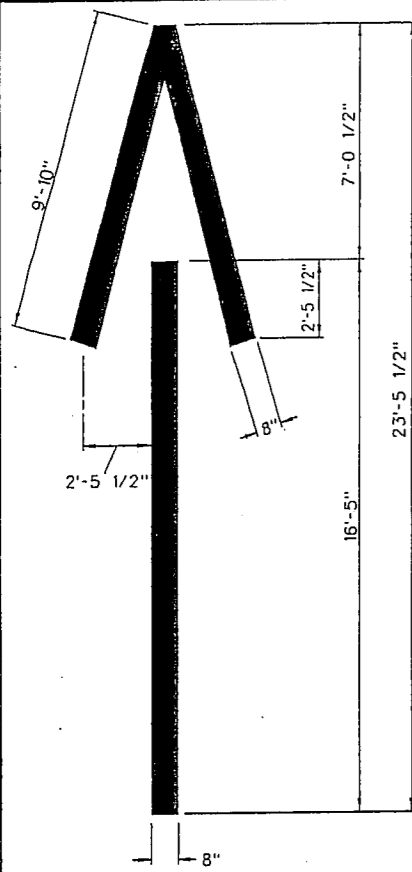

RAMP WRONG WAY ARROW
SEE NOTE 7

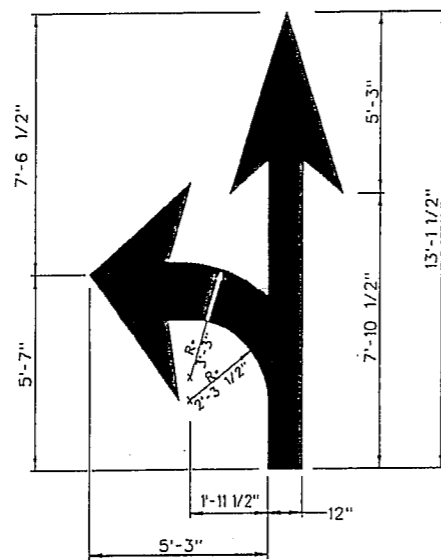

MULTI-DIRECTIONAL LANE ASSIGNMENT ARROW

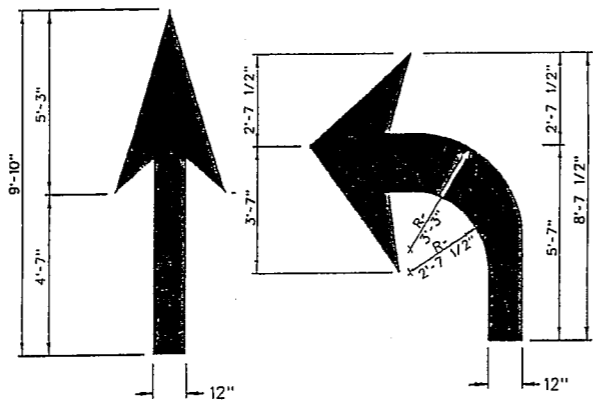

ONE DIRECTION LANE ASSIGNMENT ARROW

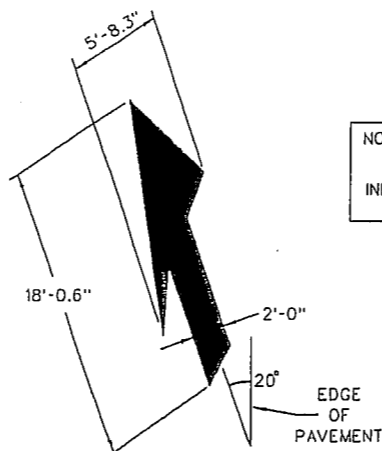

LANE DROP ARROW

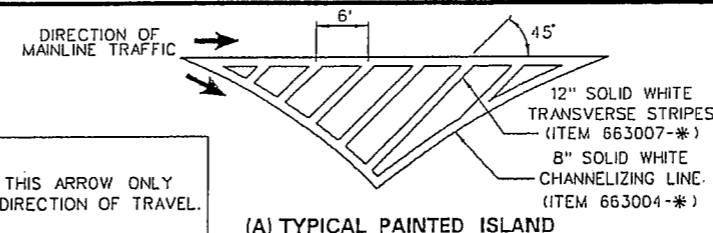

(A) TYPICAL PAINTED ISLAND

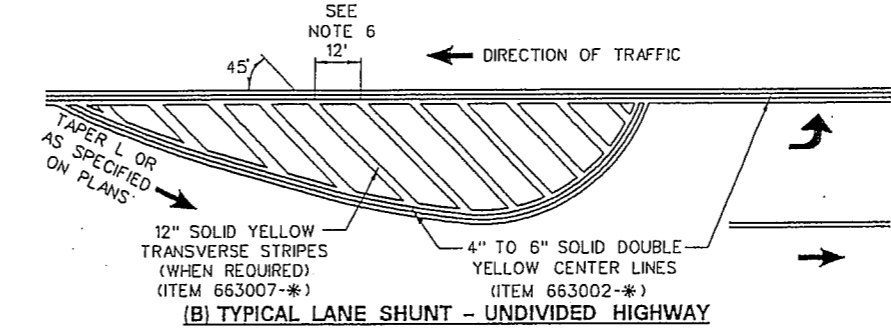

(B) TYPICAL LANE SHUNT - UNDIVIDED HIGHWAY

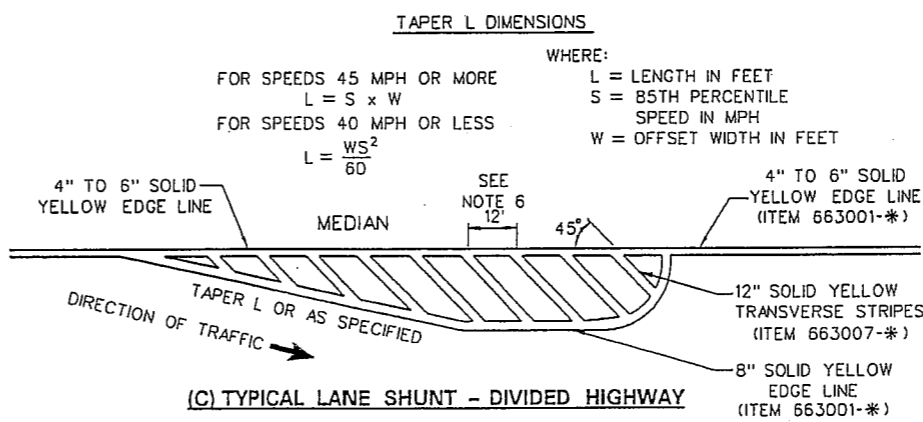

(C) TYPICAL LANE SHUNT - DIVIDED HIGHWAY

TAPER L DIMENSIONS

WHERE:
 L = LENGTH IN FEET
 S = 85TH PERCENTILE SPEED IN MPH
 W = OFFSET WIDTH IN FEET

FOR SPEEDS 45 MPH OR MORE
 $L = S \times W$

FOR SPEEDS 40 MPH OR LESS
 $L = \frac{WS^2}{60}$

TYPICAL PAVEMENT MARKING ARROWS
(ITEM 663010-*)

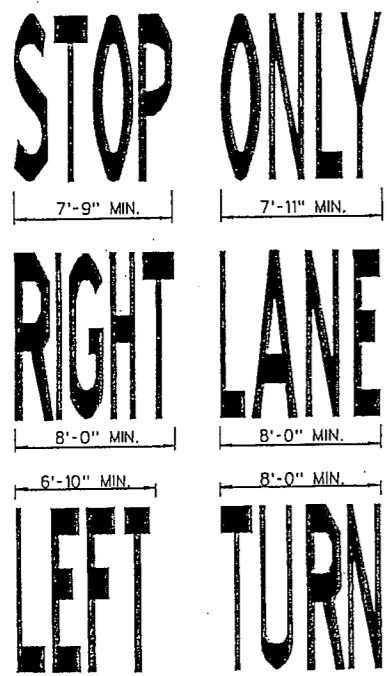

ALL LETTERS SHALL HAVE A MIN. HEIGHT OF 8'-0"
TYPICAL PAVEMENT MARKING LEGENDS
(ITEM 663011-*)

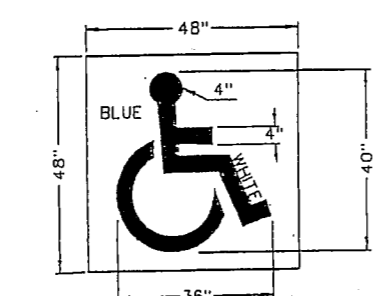

HANDICAPPED ACCESSIBLE SYMBOL
(ITEM 663009-*)

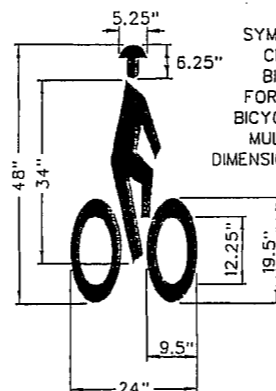

BICYCLE SYMBOL
(ITEM 663009-*)

SYMBOL SHALL BE CENTERED ON BICYCLE LANE FOR 3' OR 4' WIDE BICYCLE SYMBOLS - MULTIPLY ABOVE DIMENSIONS ACCORDINGLY

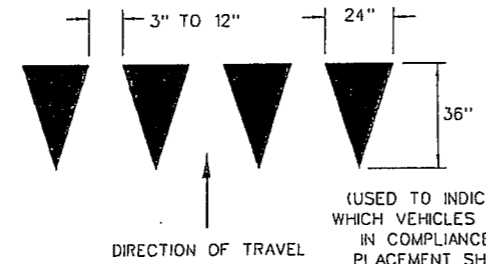

YIELD TRIANGLES
(ITEM 663008-*)

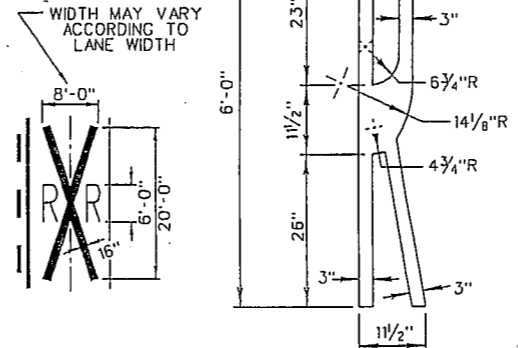

RAILROAD-HIGHWAY CROSSINGS
(ITEM 663015-*)

WEST VIRGINIA DIVISION OF HIGHWAYS
SPECIAL DETAIL
CHANNELIZATION, WORD AND SYMBOL MARKINGS

PREPARED 1/29/10

REVISIONS

REPLACES STANDARD DETAILS BOOK VOL. II SHEET TEM-3

PUBLIC ROADS DIV.	STATE DET. NO.	STATE PROJECT NO.	FEDERAL PROJECT NO.	FGCM YEAR	COMMIT	SHEET NO.	TOTAL SHEETS

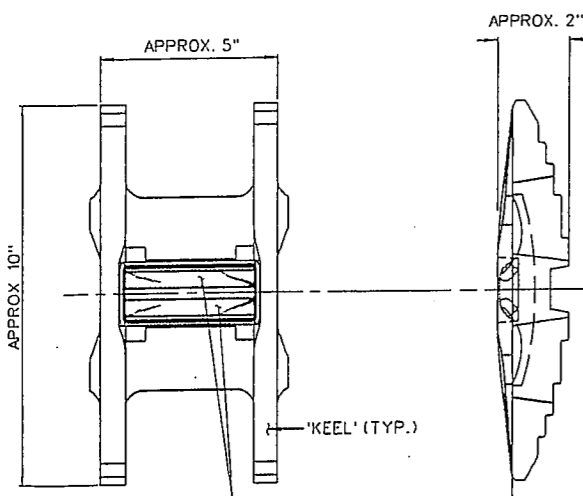

MONO DIRECTIONAL WHITE, MONO OR BI-DIRECTIONAL YELLOW, OR BI-DIRECTIONAL WHITE/RED REFLECTORS AS SPECIFIED

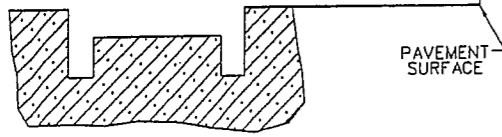

TYPICAL TYPE "P-2" MARKER
(ITEM 663012-*)

- NOTES:**
1. MARKER PLACEMENT AT GORES ONLY WHEN SPECIFIED.
 2. THE SPACING BETWEEN MARKERS IN THE GORE AREA SHOULD BE APPROXIMATELY 12' APART AND CENTERED BETWEEN THE STRIPES (IF THEY ARE EXISTING).
 3. END MARKERS APPROXIMATELY 20' BEYOND EXIT GORE SIGN OR PHYSICAL GORE IF NO SIGN.

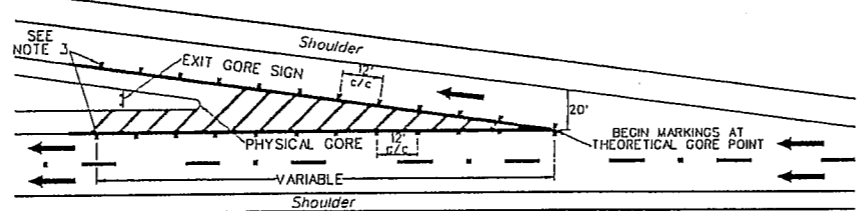

GORE AREA

- NOTES:**
1. MARKINGS FOR DIVIDED ROADWAY IS SHOWN. USE MONO-DIRECTIONAL (WHITE) FOR UNDIVIDED APPLICATIONS.

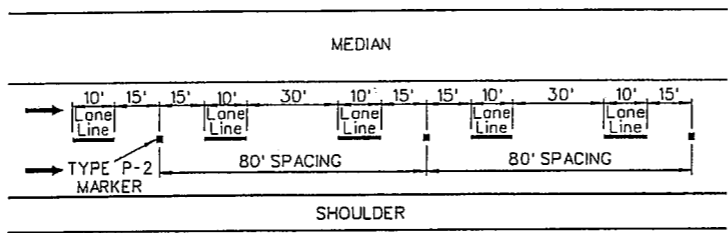

LANE LINE OF DIVIDED HIGHWAY

- NOTES:**
1. SEE THE APPROVED PRODUCTS LIST (APL) FOR APPROVED TUBULAR MARKERS.
 2. CHANNELIZING LINE SHALL ONLY BE PLACED BETWEEN R-4's AND TUBULAR MARKERS AND SHALL NOT BE CONTINUOUS. THE R-4's AND TUBULAR MARKERS SHALL BE PLACED ON BARE PAVEMENT.

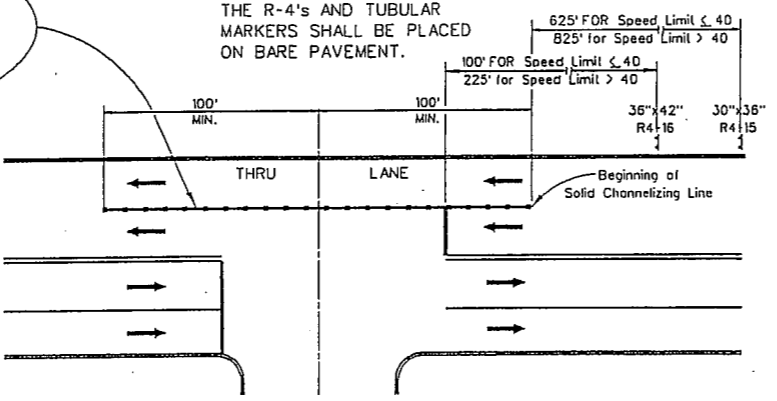

CONTINUOUS THRU LANE SIGNING AND DELINEATION

- GENERAL NOTES**
1. LOCATION OF MARKERS ARE SHOWN ON THE PLANS.
 2. TYPE R-4 MARKERS ARE NOT TO BE APPLIED OVER PAINT STRIPING.
 3. ALL TYPE P-2 AND R-4 MARKER SHALL BE INSTALLED IN ACCORDANCE WITH THE STANDARD SPECIFICATIONS.
 4. THE R-4 MARKERS UTILIZED SHALL BE EITHER 3M MODEL PSA/290/291 OR ENNIS PAINT MODEL C80.

- NOTES:**
1. MARKINGS FOR DIVIDED ROADWAY IS SHOWN. USE MONO-DIRECTIONAL (WHITE) FOR UNDIVIDED APPLICATIONS.

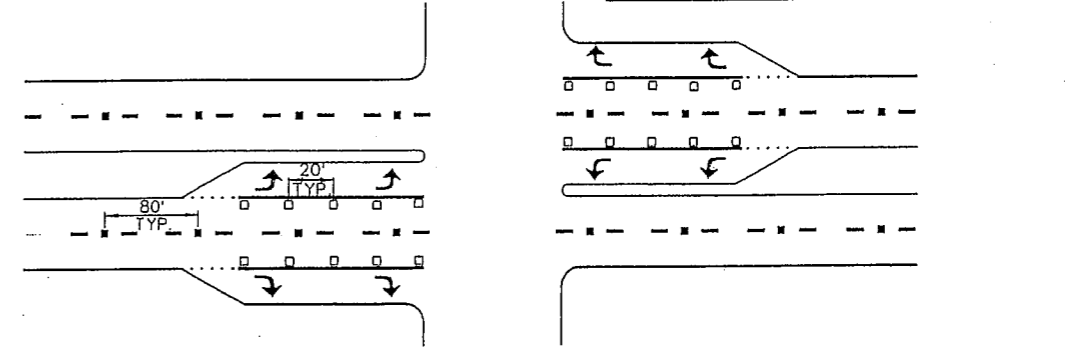

MULTI-LANE ROADWAY WITH AT-GRADE INTERSECTION

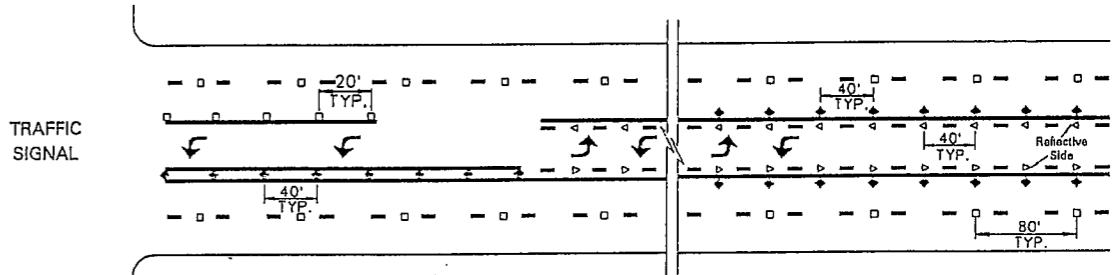

MULTI-LANE ROADWAY WITH TWO-WAY LEFT TURN LANE

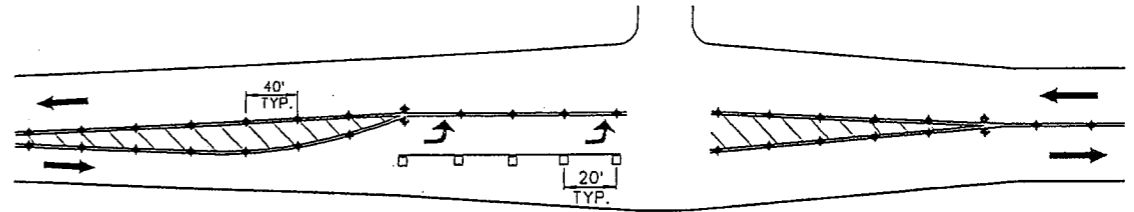

TWO LANE HIGHWAY WITH LEFT TURN BAY

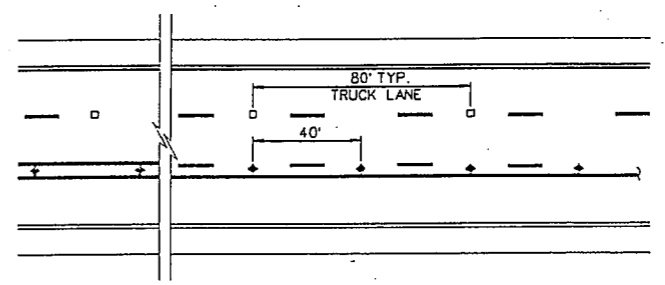

TWO LANE HIGHWAY WITH TRUCK CLIMBING LANE

- LEGEND**
- - BI-DIRECTIONAL (WHITE/RED) WITH WHITE REFLECTOR FACING TRAFFIC
 - - MONO-DIRECTIONAL (WHITE)
 - ◆ - BI-DIRECTIONAL (YELLOW)
 - ▷ - MONO-DIRECTIONAL (YELLOW)

NOTE:
← THIS ARROW ONLY INDICATES DIRECTION OF TRAVEL.

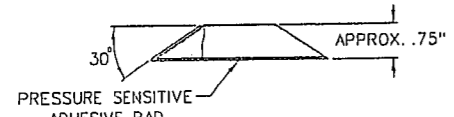
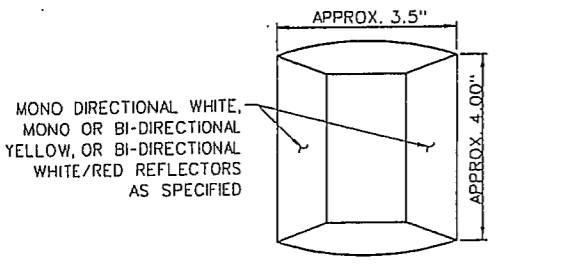

TYPE "R-4" MARKER
(ITEM 663012-*)

OPTION: R-4 MARKERS WITHOUT PRESSURE SENSITIVE ADHESIVE PAD MAY BE INSTALLED USING ADHESIVE RECOMMENDED BY THE MANUFACTURER

WEST VIRGINIA DIVISION OF HIGHWAYS
SPECIAL DETAIL PAVEMENT MARKERS TYPES "P" and "R"

PREPARED 1/29/10

REVISIONS

REPLACES STANDARD DETAILS BOOK VOL. II SHEET TEM-4